

FEATURES:

- IEEE 802.3af&at/ANSI X3.263 compliant performance
- Suitable for End-span and Mid-span PoE applications
- 350&600mA current capability
- Designed for IP phone or switch applications
- Compact footprint
- Designed to withstand IR reflow temperatures up to 240°C
- Recognized by UL 60950-1

YUAN DEAN SCIENTIFIC



LAN Filters

PoE 15FB SERIES

10/100/1000 Base-TX

PoE & PoE+

SMD

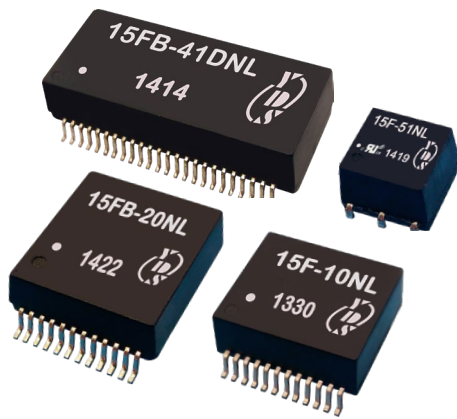

Electrical Specifications@25°C-Operating Temperature 0°C to 70°C

Part Number	Ports	Insertion Loss (dB max)	Return Loss (dB MIN @100Ω)				Differential to Common Mode Rejection (dB MIN)			Crosstalk (dB MIN)			Hipot (Vrms MIN) @60Hz	POE Current
			1-100 MHz	1-30 MHz	40 MHz	50 MHz	60-80 MHz	30 MHz	60 MHz	100 MHz	30 MHz	60 MHz		
15FB-40NL	4	-1.2	-16	-14	-13	-12	-43	-37	-33	-45	-40	-30	1500	350mA
15FB-83NL	1	-1.2	-18	-14	-13	-12	-	-	-	-41	-37	-33	1500	750mA
15FB-41NL	2	-1.2	-16	-14	-13	-12	-43	-37	-30	-35	-30	-25	1500	600mA
15FB-73NL	2	-1.0	-18	-14.4	-13.1	-12	-43	-37	-33	-45	-40	-35	1800	350mA
15FB-62NL	1	-1.2	-14	-	-12	-10	-	-	-	-	-	-30	1500	1.5A
15FB-30NL	1	-1.2	-16	-14	-13	-12	-43	-37	-33	-45	-40	-35	1500	600mA
15FB-52NL	-	-1.0	-16	-13.5	-11.6	-10	-	-	-	-	-	-30	1500	720mA
15FB-10NL	1	-1.2	-16	-14	-13	-12	-43	-37	-33	-43	-37	-31	1500	350mA
15FB-21NL	2	-1.0	-18	-18	-16	-12	-43	-37	-30	-43	-37	-33	1500	600mA



Mechanicals

15FB-8X

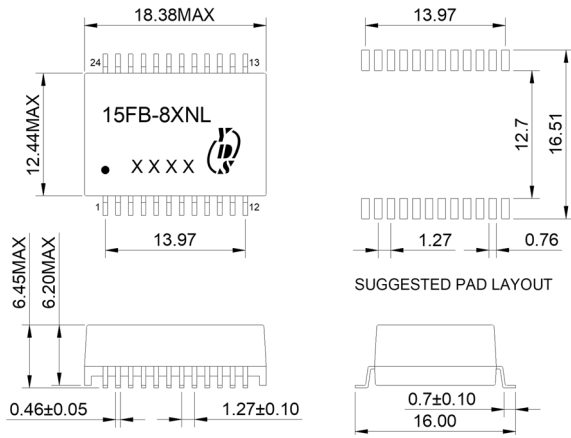

15FB-6X

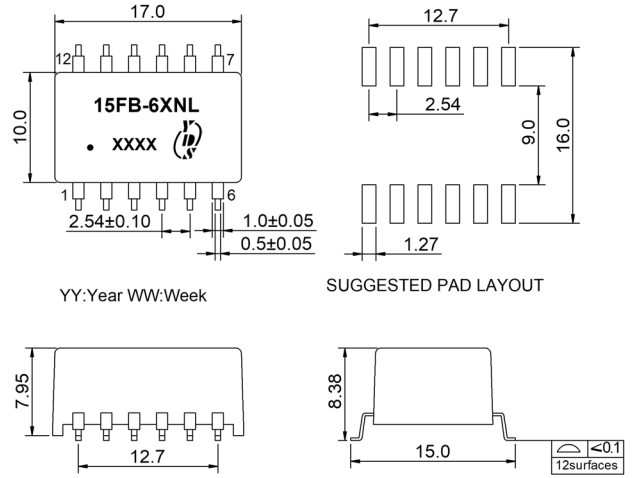

15FB-7X

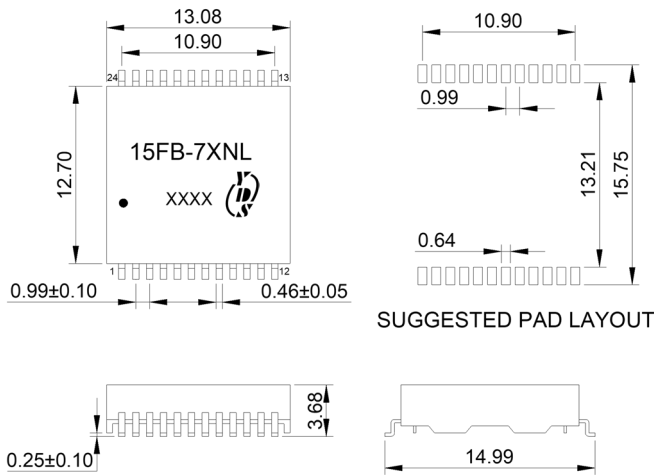

15FB-2X

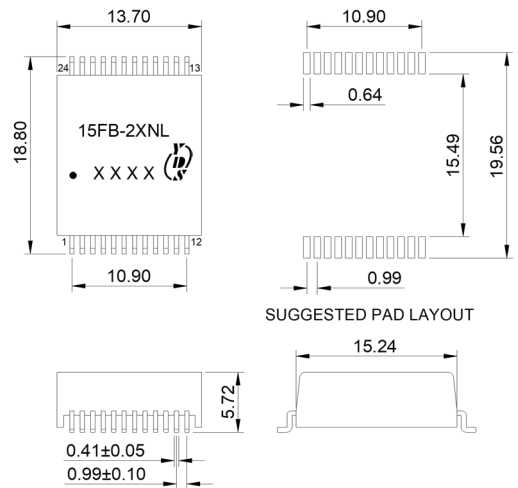

15FB-4X

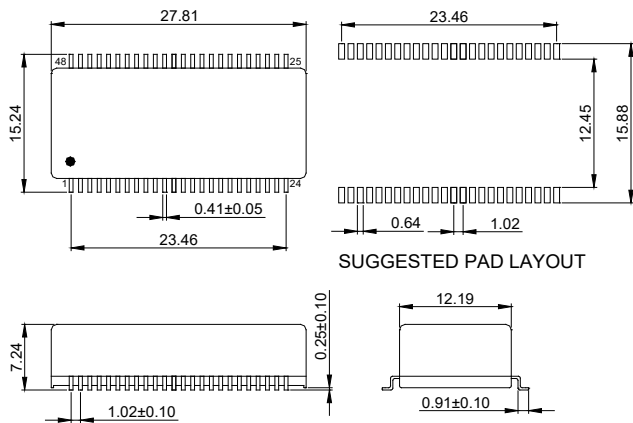

15FB-5X

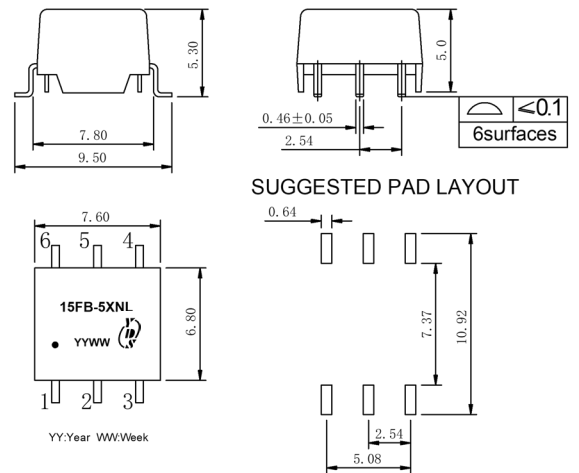

Mechanicals

15FB-3X

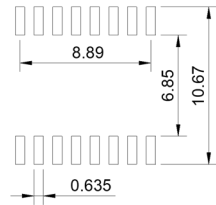
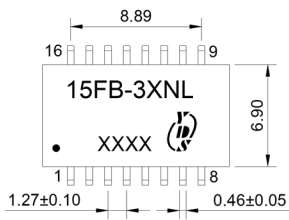

SUGGESTED PAD LAYOUT

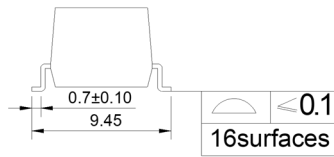
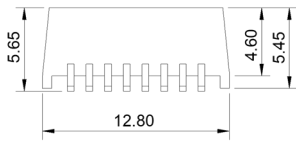

15FB-1X

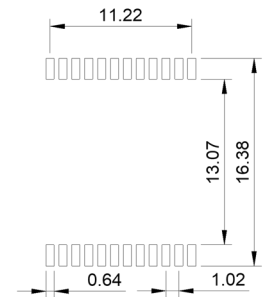
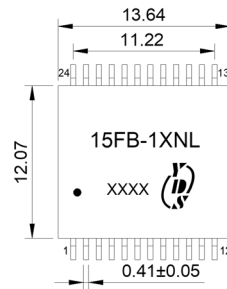

SUGGESTED PAD LAYOUT

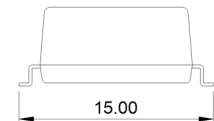
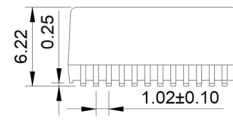

Schematics

15FB-40

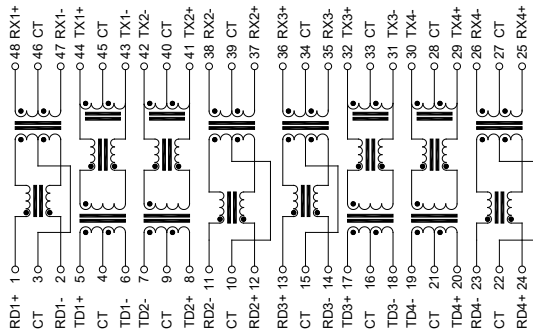

15FB-42

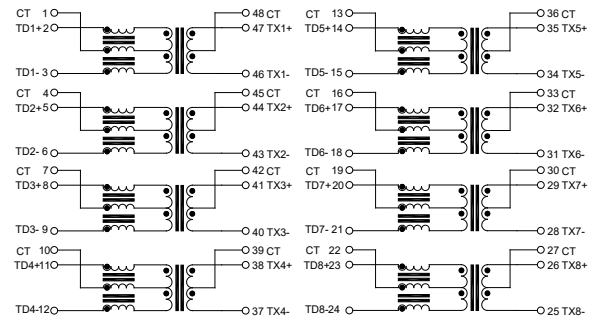

15FB-81

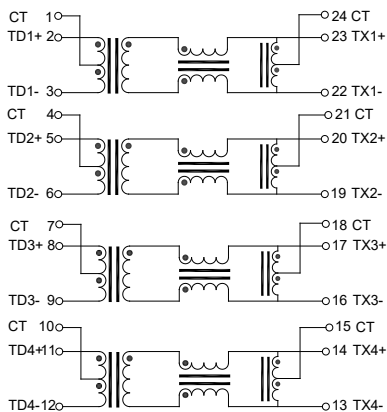

15FB-83

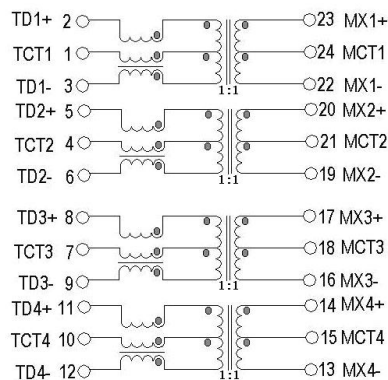

15FB-84

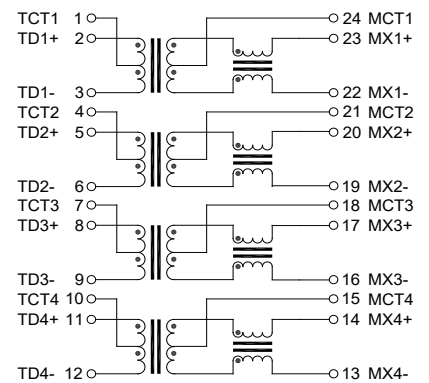

Schematics

15FB-89

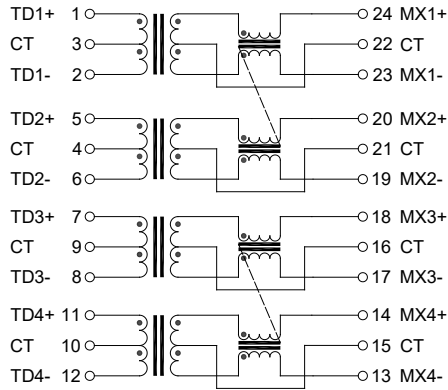

15FB-48

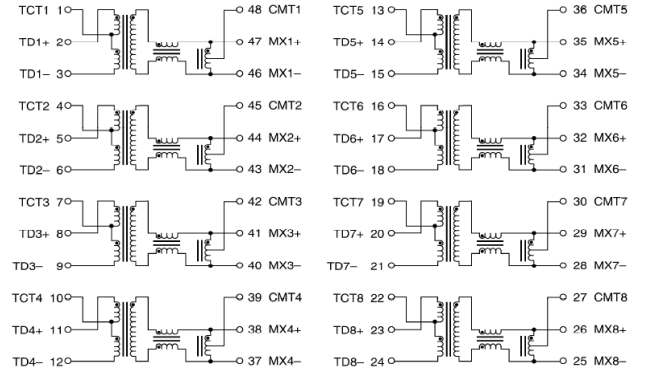

15FB-41

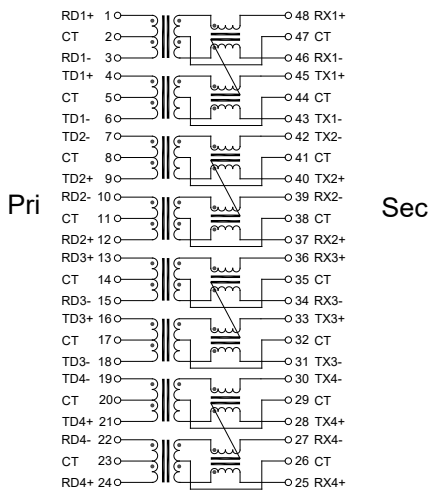

15FB-47

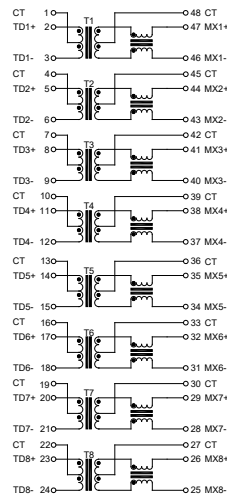

15FB-4G

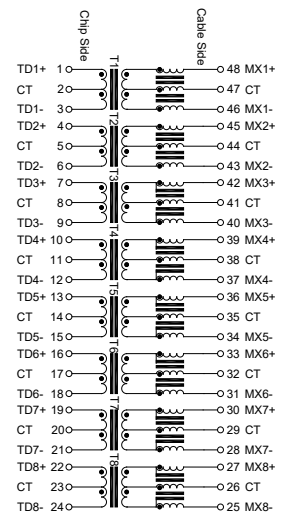

15FB-60

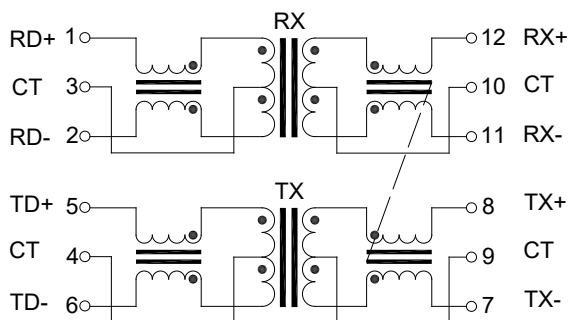

15FB-61

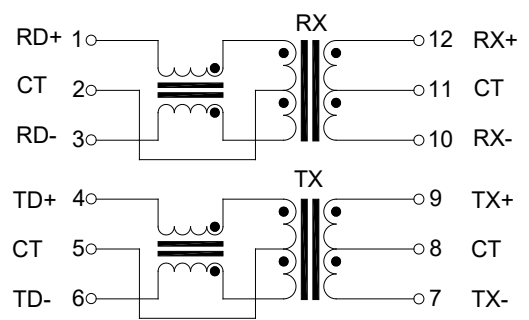

Schematics

15FB-62

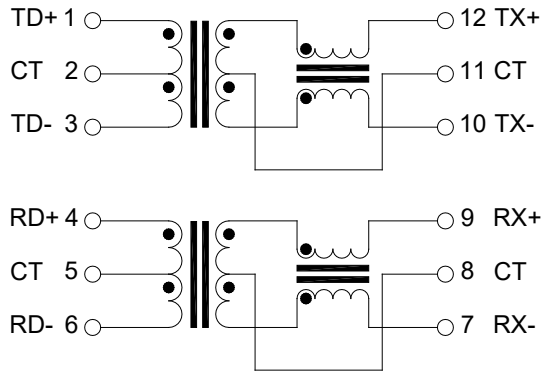

15FB-52

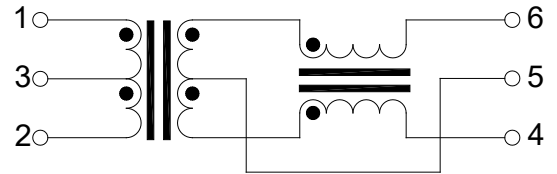

15FB-10

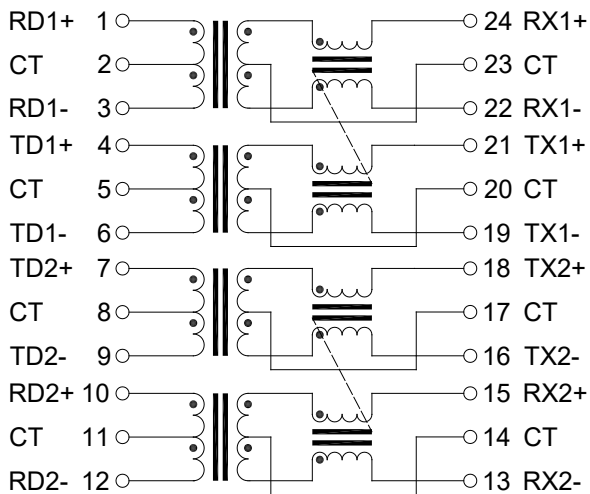

15FB-21

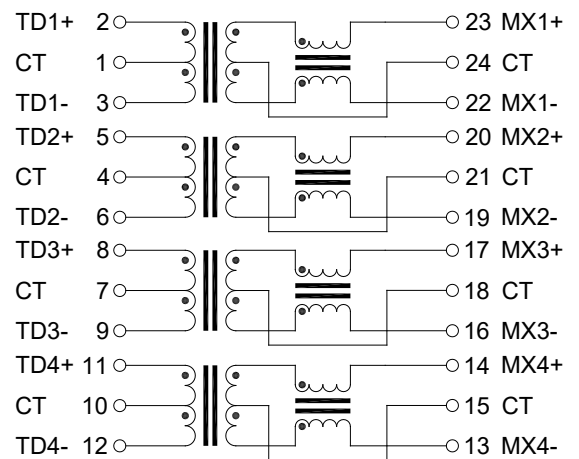

15FB-30

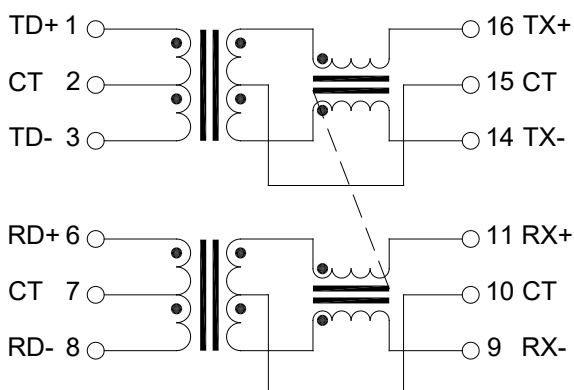

15FB-36

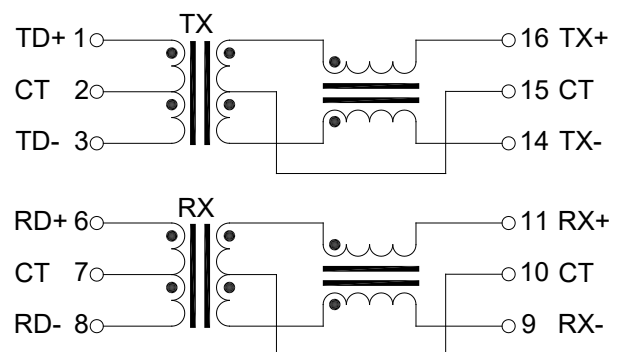

Schematics

15FB-72

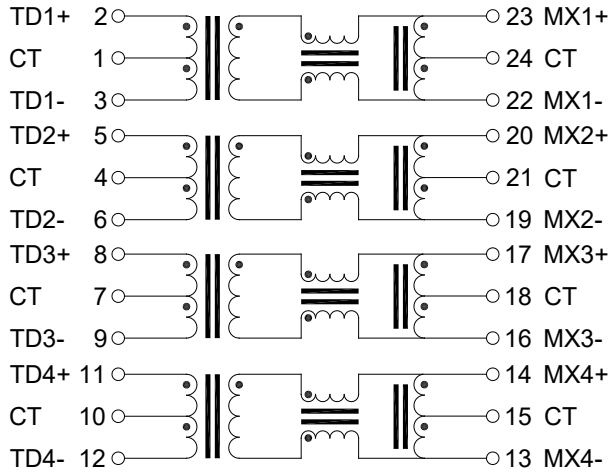

15FB-73

